

A2000

Bidirection Programmable AC Power Supply





Application
Scenarios

01



Why need?

02



A2000
Solution

03



Product
Portfolio

04



Our Clients

05



Application
Scenarios
01



Why need?
02



A2000
Solution
03



Product
Portfolio
04



Our Clients
05

Application Scenarios

MORE PRECISE AND CONVENIENT

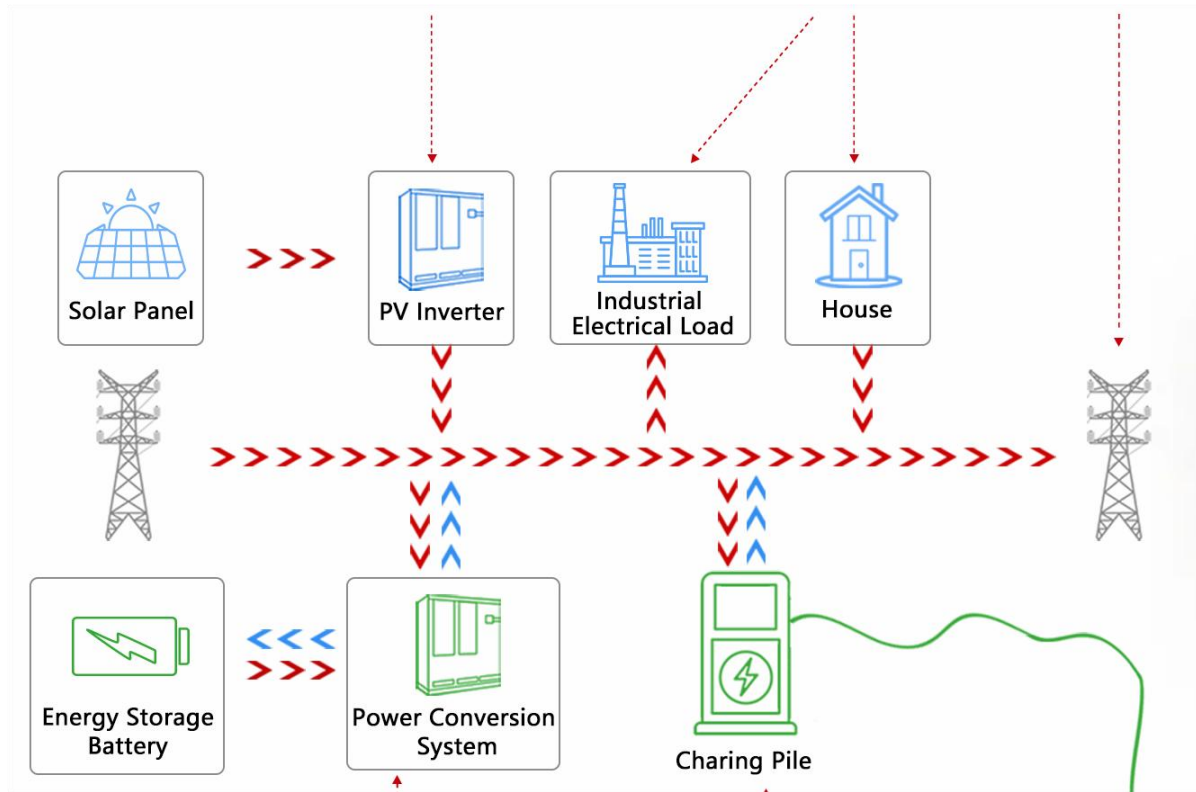

All devices connected to the grid, usually require AC power supply.

Especially new energy power generation devices.

Application Scenaires

MORE PRECISE AND CONVENIENT

Typical applications of new energy generation & EV

ITEM	PV Inverter	Wind Power Converter	Power Conversion System	DC Charging Pile	OBC
Power range	2.5 kVA - 330 kVA 300 kVA - 4000 kVA	~6MVA	30 kVA - 4400 kVA	30kW~240kW 360kW/480kW	6kW~30kW



Application
Scenarios

01



Why need?

02

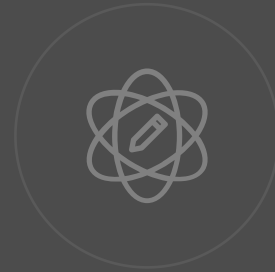

A2000
Solution

03



Product
Portfolio

04



Our Clients

05

Why need?

What characteristics need to be simulated by the grid simulator?

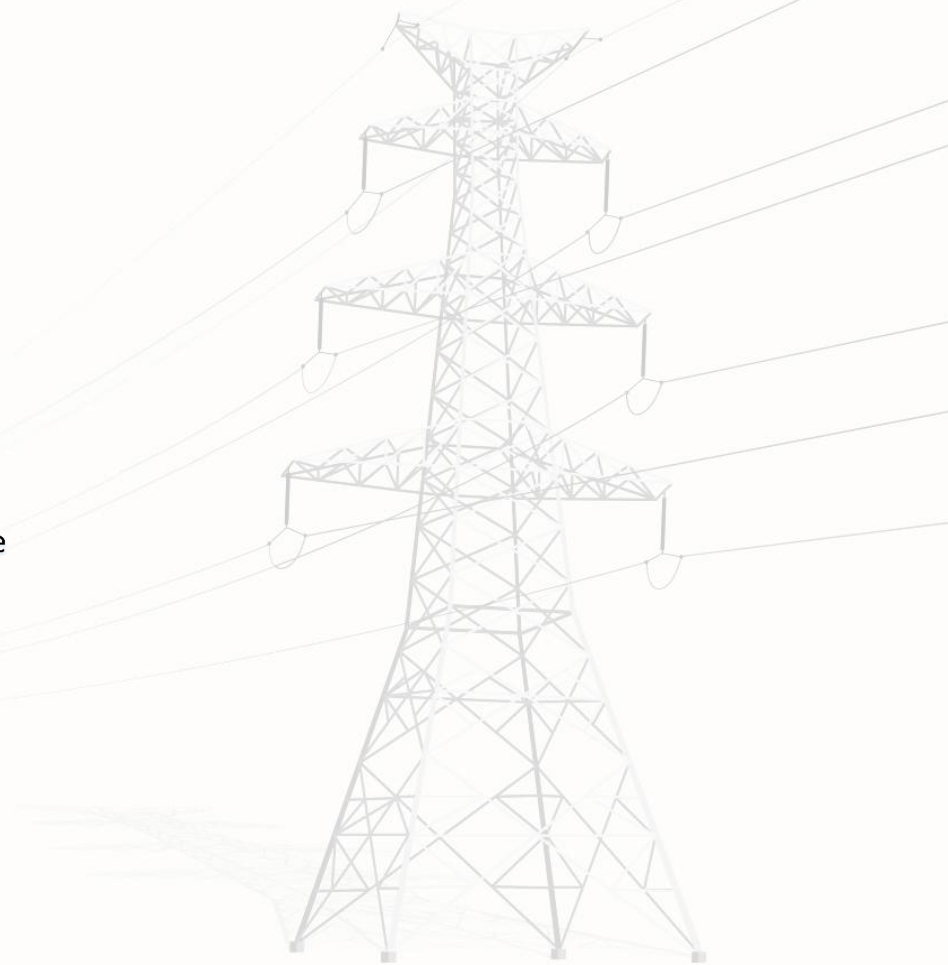
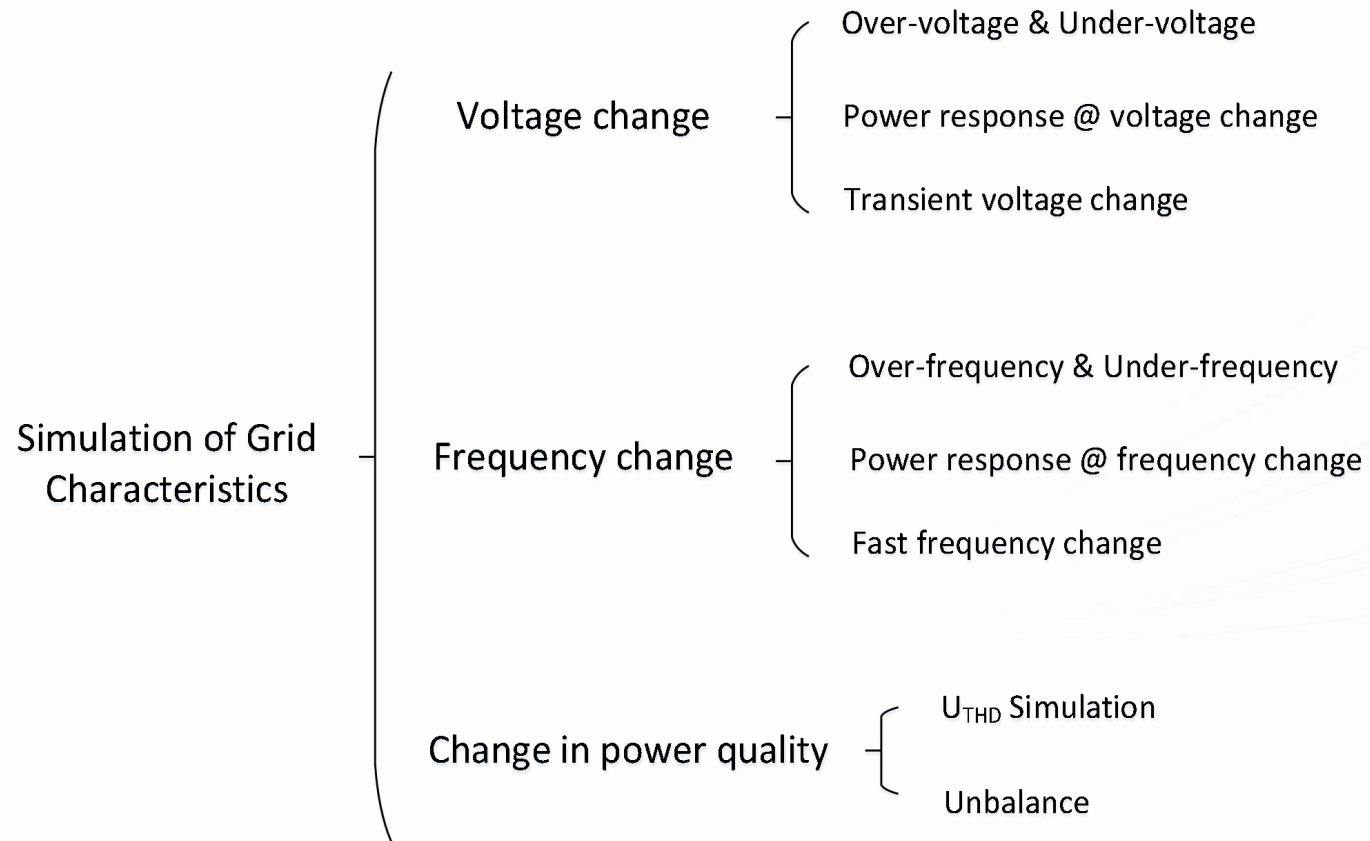

Why need?

Distributed network has clear requirements for grid-connected generation equipment, such as:

No.	Items	Regulations
1	Continuous operating voltage range	EN 50549-1:2019 4.4.4 IEEE 1547.1-2020 5.4.2&5.4.3 NB/T 32008-2018 8.3.4
2	Requirements on voltage and frequency protection	EN 50549-1:2019 4.9.3 IEEE 1547.1-2020 7.2&7.3 VDE-AR-N 4105:2011 6.5.2 NB/T 32008-2018 9.1.2@9.2
3	Power response to voltage changes	EN 50549-1:2019 4.7.2&4.7.3 IEEE 1547.1-2020 5.14.4&5.14.5&5.14.6&5.14.9&5.14.10 NB/T 32008-2018 8.3.3&8.3.5.3
4	Low-voltage ride through (LVRT)	EN 50549-1:2019 4.5.3 IEEE 1547.1-2020 5.4.4 NB/T 32008-2018 8.3.5.1.1
5	High-voltage ride through (HVRT)	EN 50549-1:2019 4.5.4 IEEE 1547.1-2020 5.4.7 NB/T 32008-2018 8.3.5.1.2
6	Operating frequency range	EN 50549-1:2019 4.4.2 IEEE 1547.1-2020 5.5.1&5.5.2 NB/T 32008-2018 8.3.6

Why need?

Distributed network has clear requirements for grid-connected generation equipment, such as:

No.	Items	Regulations
7	Power response to overfrequency /underfrequency	EN 50549-1:2019 4.6.1&4.6.2 IEEE 1547.1-2020 5.15.2&5.15.3 VDE-AR-N 4105:2011 5.7.3.3&5.7.3.4 NB/T 32008-2018 8.3.2
8	Voltage fluctuations & flickering adaptability	NB/T 32008-2018 8.3.7.4 VDE-AR-N 4105:2011 5.4.2&5.4.3 GB/T 12326
9	Harmonics adaptability	NB/T 32008-2018 8.3.7.1 VDE-AR-N 4105:2011 5.4.4 GB/T 14549
10	Inter-harmonics adaptability	NB/T 32008-2018 8.3.7.2 VDE-AR-N 4105:2011 5.4.4 GB/T 24337
11	3-phase voltage unbalance adaptability	NB/T 32008-2018 8.3.7..3 VDE-AR-N 4105:2011 5.4.5 IEEE 1547.1-2020 5.4.5 GB/T 15543
12	Open phase	IEEE 1547.1-2020 5.11 NB/T 32004-2018 9.3.2
13	Automatic reconnection after tripping	EN 50549-1:2019 4.10.2 NB/T 32008-2018 9.8



Application
Scenarios

01



Why need?

02



A2000
Solution

03



Product
Portfolio

04



Our Clients

05

Introduction-A2000

Grid Simulator

1. A2000 series is a bidirectional programmable AC power supply.
2. A2000 series adopts SiC design of the third-generation wide band gap semiconductor devices.
3. The modular and standardized design gives the A2000 excellent steady-state accuracy and fast dynamics.

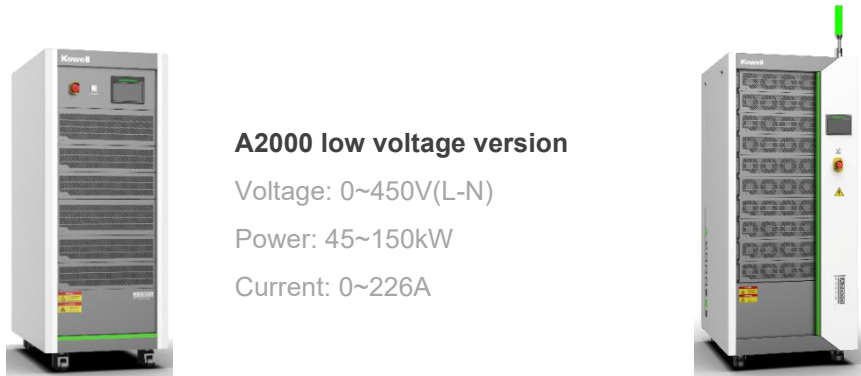

A2000 low voltage version

Voltage: 0~450V(L-N)

Power: 45~150kW

Current: 0~226A

A2000 high voltage version

Voltage: 0~900V(L-N)

Power: 100~500kW

Current: 0~500A

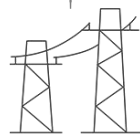

Grid

MORE PRECISE AND CONVENIENT

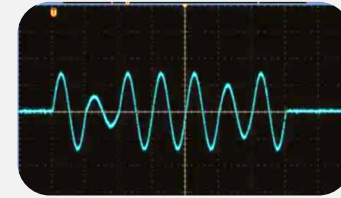

Instantaneous voltage drop in the grid

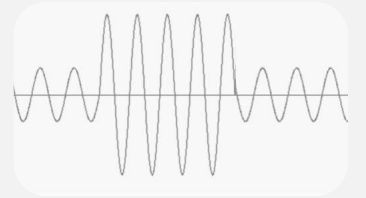

Instantaneous voltage rise in the grid

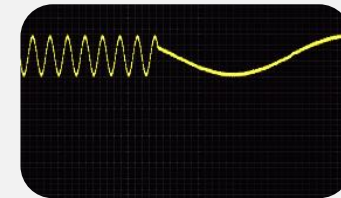

Frequency fluctuations

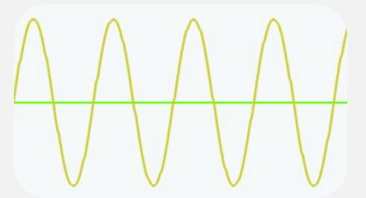

Simulation of power grids in different countries and regions

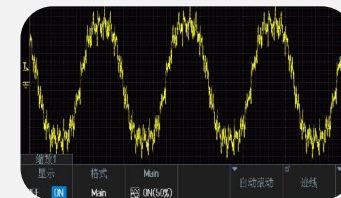

Deterioration of grid power quality

Typical Applications— PV & Energy Storage Testing

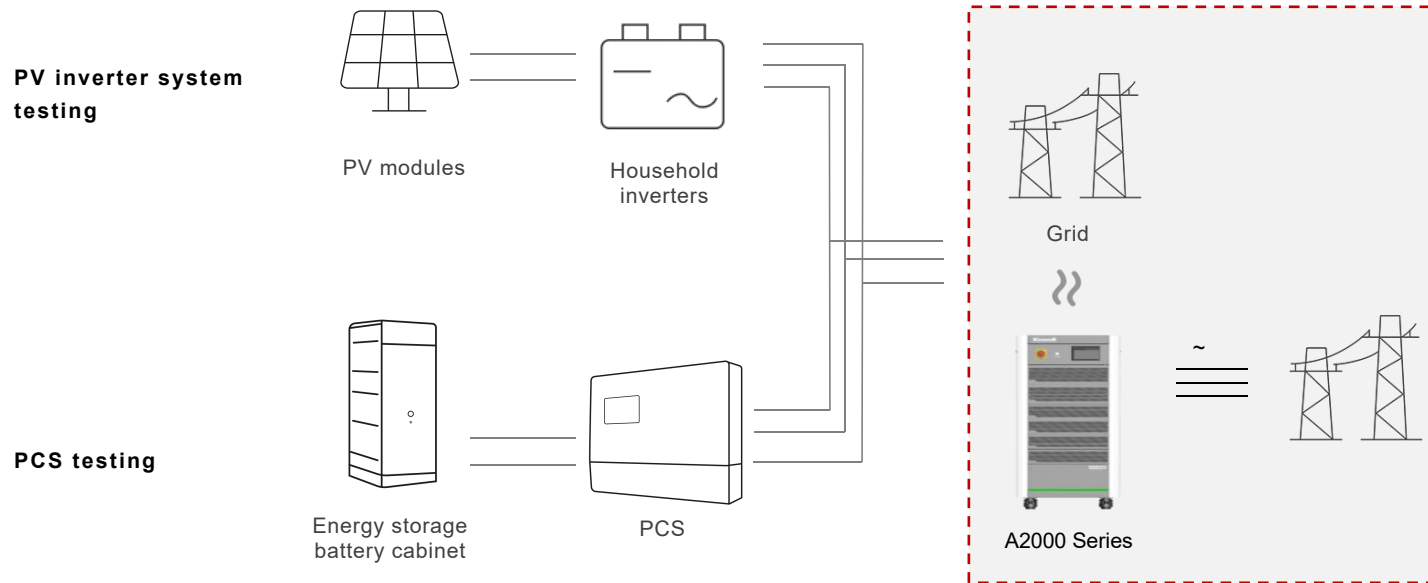

MORE PRECISE AND CONVENIENT

Grid simulation

1. Simulate grid voltages of different countries and regions
2. Simulate deterioration of grid power quality
3. Simulate grid voltage changes
4. Simulate grid voltage drops

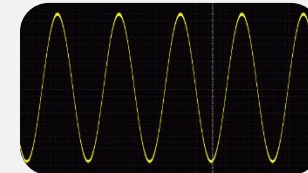

Simulation of power grids in different countries and regions

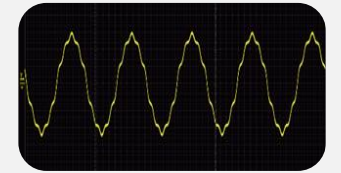

Harmonic injection

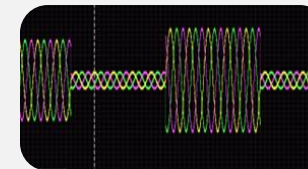

HVRT&LVRT

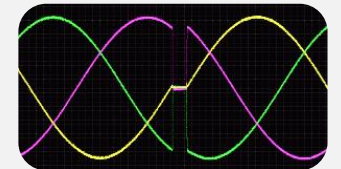

1ms ZVRT

Typical Applications—AC Charging Pile Testing

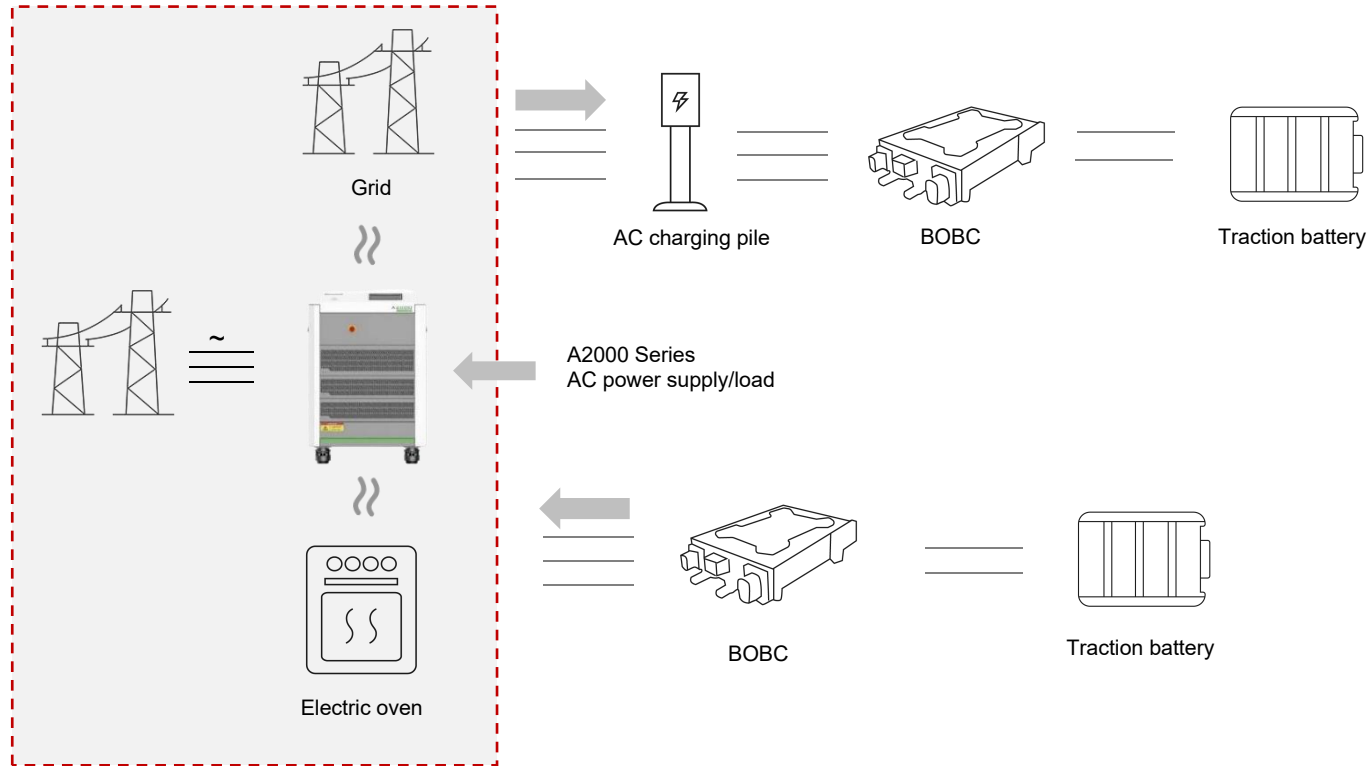

MORE PRECISE AND CONVENIENT

Grid and AC Load Simulation

1. Simulate grid voltages of different countries and regions
2. Simulate deterioration of grid power quality
3. Simulate grid voltage changes
4. BOBC converts AC to DC to charge the battery; V2L mode; through BOBC, traction battery converts DC to AC to supply power to AC loads, i.e., testing EV external discharge function

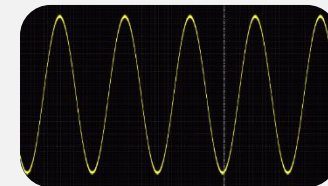

Simulation of power grids in different countries and regions

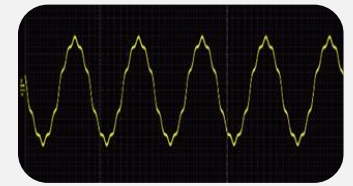

Harmonic injection

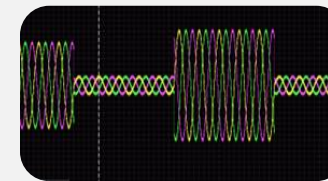

HVRT&LVRT

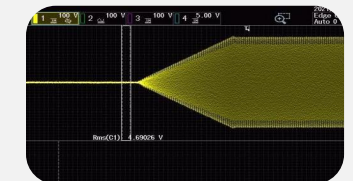

AC loading test

Typical Applications—DC Charging Pile Testing

MORE PRECISE AND CONVENIENT

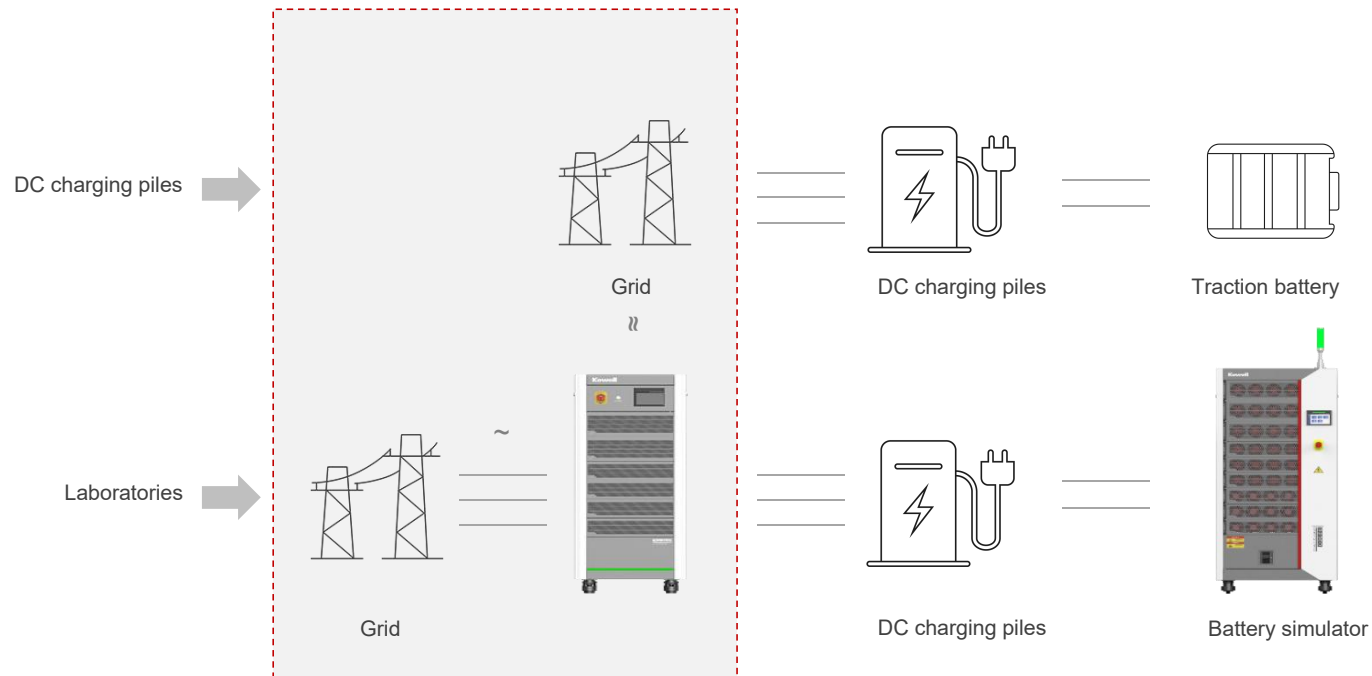

Grid Simulation

1. Simulate grid voltages of different countries and regions
2. Simulate deterioration of grid power quality
3. Simulate grid voltage changes
4. Simulate grid frequency fluctuations

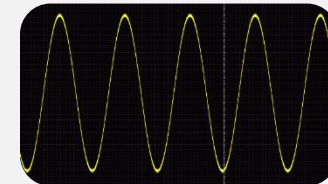

Simulation of power grids in different countries and regions

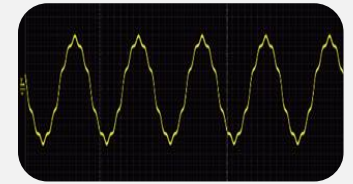

Harmonic superposition

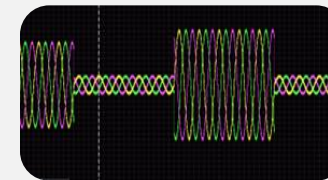

HVRT&LVRT



Frequency fluctuations



Application
Scenarios

01



Why need?

02



A2000
Solution

03



Product
Portfolio

04



Our Clients

05

Introduction-A2000

NORMAL

Fundamental, Cost-effective

PRO

Fully-featured, Multi-scenario

Ultra

Ultimate experience, Lab testing-oriented

		Normal	Pro	Ultra
Functions	AC source	•	•	•
	General AC load	-	•	•
	RLC load	-	-	•
	Communication interfaces RS485/LAN/CAN	•	•	•
Output parameters	Voltage accuracy	±0.1%F.S.		±0.05%F.S.
	Frequency range	40~70 Hz.		40~100 Hz.
	Output THD	< 0.5%@50Hz/60Hz no-load < 1%@50Hz/60Hz Linear Load		< 0.2%@50Hz/60Hz no-load < 0.8%@50Hz/60Hz Linear Load
	Min. transition time (10%-90%Umax)	< 800μs		< 500μs
	Current accuracy	±0.1%RD+0.2%F.S.		0.2%F.S.
	Harmonic range	50 Harmonic order@50Hz/60Hz		70 Harmonic order@50Hz/60Hz
	Voltage slew rate	AC > 1V/μs		

MORE PRECISE AND CONVENIENT

	Power/kW	Voltage/V	Current/A
Low voltage	45-225	0-450	0~342
High voltage	100-500	0-900	0~500



Comparing with G6000

Model	A2000	G6000
Power Range	45kW~225kW 4types 100kW~500kW 5types	18kW
Voltage Range	L: 0~450Vac (L-N) H: 0~900Vac(L-N)	0~450Vac (L-N)
Current	500A(max)	30A 3Phases 90A 1Phase
Output Frequency	40~70Hz 40~100Hz	15~200Hz(~5kHz in the future)
Dimensions(W*D*H)[mm]	620-900-1020 @75kW	3U454*699*133
Output	AC	AC / DC / AC+DC / DC+AC
Programming	List/Pulse/Step, Harmonic&Interharmonic, HVRT&LVRT, Unbalance, Flickering, Transient	Sine wave, List/Pulse/Step, Harmonic&Interharmonic, Special waves, Advanced applications
Harmonics	Up to 70 Harmonic order@50Hz/60Hz	2-100 Harmonic order(5kHz max)
Load Function	●	●

• G6000



• A2000



Kewell

We are dedicated to becoming a global test equipment supplier covering versatile application industries based on test power supplies.

www.kewelltest.com